

**Book**

**ON**

**Integrated Skill Development Training Program**

**Conducted**

**AT**

**Metal Handicrafts Service Centre**

**Quality Control**

Course: Quality Control & Inspection

Duration: 220Hrs.

Ch. Nos.	Chapters	Topics Covered	Duration
1	Principles and Concept of Quality Control (QC) and Quality Assurance (QA)	<ol style="list-style-type: none"> <li>1. Concept of Quality, Aspects of Quality, Definition of QC and QA, Advantages and Disadvantages of Quality Control, Quality Principles, Quality policy, Quality Planning, Cost of Poor Quality, Cost Reduction through Quality Improvement.</li> <li>2. Importance of Quality, Difference b/n QC &amp; QA, Important of QC, Choosing best Quality Control Methods,</li> <li>3. Importance of Quality Assurance. Total Quality Assurance, Management principles in Quality Assurance, Forms of Quality Assurance, Evaluation of Quality Assurance, Quality Assurance Programme, Quality Assurance aspects, Quality Assurance Departments.</li> </ol>	20 Hrs.
2	Inspection	Definition of Inspection, Inspection Planning, Types of Inspection, Measurement Errors, Objectives of Inspection, Floor/ patrol Inspection, Centralized Inspection, Process Inspection, Final Inspection, Difference between Inspection & Quality Control, AQL Concept	60 Hrs.
3	QC in Handicraft Industry Part -1	Product Life Cycle (Fabrication, Finishing, Packaging, Loading), Stages of Production, Production Process of Metal wares, Technique for Quality Control in Productions, Total Quality Control	40 Hrs.
4	QC in Handicraft Industry Part -2	Concept of Drop Test, Product Labelling, Types of Product Packaging, Importance Product Packing,	40 Hrs.
5	QC Techniques and Application	Quality Control Methods Tools, Various QC process, Stages of QC in product life cycle	20 Hrs.
6	QC Techniques and Application, Quality Audit	Types of International Product Testing, Product Testing Standards and Minimum Accepted value, ROHS, LEAD Testing, Transit Testing, ASTM	20 Hrs.
7	Quality Management Systems: ISO 9000, TQM, QMS in Handicraft Industry	Quality Management systems – Origin of ISO 9000 series ( ISO 9001,9002,9003,9004) ISO 9001:2000, Clauses of ISO 9001:2000, overview of QS 9000 series	20 Hrs.

# Chapter- 1

## Principles and Concept of Quality Control (QC) and Quality Assurance (QA)

---

---

1. **Concept of Quality:** Quality is important to business but can be quite hard to define. A good definition of quality is : **“Quality is about meeting the need and expectations of customers”**
2. **Aspects of Quality:** customers want quality that is appropriate to the price that they are prepared to pay and the level of competition in the market.

Key aspects of quality for the customer include:

- Good Design- Looks and style
- Good functionality- it does the job well
- Reliable- acceptable level of breakdowns or failure
- Consistency
- Durable- lasts as long as it should
- Good after sales service
- Value for money

**‘Value for money’ is especially important,** because in most markets there is room for products of different overall levels of quality, and the customer must be satisfied that the price fairly reflects the quality.

### **Importance of quality: or: Why quality is important to a growing business?**

Good quality helps determine a firm’s success in a number of ways:

- **Customer loyalty-** They return, make repeat purchases and recommended the product of service to other.
- Strong brand reputation for quality
- Retailers want to stock the product
- As the product is perceived to be better value for the money, it may command a premium price and will become more price inelastic
- Fewer returns and replacements lead to reduced costs

- Attracting and retaining good staff

These points can each help support the marketing function in a business. However, firms have to work hard to maintain and improve their reputation for quality, which can easily be damaged by a news story about a quality failure

### 3. **Quality Control: Definition, Advantages and Disadvantages**

Achieving high quality does not happen by accident. The production process must be properly managed to achieve quality standard. Quality management is concerned with controlling activities with the aim of ensuring that products and services are fit their purpose and meet the specifications.

There are two alternative approaches to managing quality

#### **Quality Control:**

**“The process of inspection products to ensure that they meet the required quality standards”**

Quality control involves setting standards about how much variation is acceptable. The aim is to insure that a product is manufactured, or a service is provided, to meet the specifications which ensure customer needs are meet.

At its simplest quality control is achieved through **inspection**. For example, in a manufacturing business, trained inspectors examine samples of work-in –progress and finished goods to ensure standards are being met.

This method checks the quality of completed products for faults. Quality inspectors measure or test every product, sample from each batch, or random samples- as appropriate to the kind of product produced.

The **main objective of quality control** is to ensure that the business is achieving the standards it sets for itself.

In almost every business operation, it is not possible to achieve perfection. For example there will always be some variation in terms of materials used, production skills applied, reliability of the finished product etc.

**Advantages of quality control:** with quality control, inspection is intended to prevent faulty products reaching the customer. This approach

means having specially trained inspectors, rather than every individuals being responsible for his or her own work. Furthermore, it is thought that inspectors may be better placed to find widespread problem across an organization.

**Disadvantage of quality control:** A major problem is that individuals are not necessarily encouraged to take responsibility for the quality of their own work. Rejected product is expensive for a firm as it has incurred the full costs of production but cannot be sold as the manufacturer does not want its name associated with substandard product. Some rejected product can be re-worked, but in many industries it has to be scrapped – either way rejects incur more costs,

A quality control approach can be highly effective at preventing defective products from reaching the customer. However, if defect levels are very high, the company's profitability will suffer unless steps are taken to tackle the root causes of the failures

**Quality Principles:** “A quality management principle is a comprehensive and fundamental rule/ belief, for leading and operating an organization, aimed at continually improving performance over the long term by focusing on customers while addressing the needs of all other stake holders”

The eight principles are

- 1: CUSTOMER FOCUS
- 2: LEADERSHIP
- 3: INVOLVEMENT OF PEOPLE
- 4: PROCESS APPROACH
- 5: SYSTEM APPROACH TO MANAGEMENT
- 6: CONTINUAL IMPROVEMENT
- 7: FACTUAL APPROACH TO DECISION MAKING
- 8: MUTUALLY BENEFICIAL SUPPLIER RELATIONS

Now let us examine the principles in details.

**Principle 1 – Customer focus:** Organizations depend on their customers and therefore should understand current and future customer needs, should meet customer requirements and strive to exceed customer expectations.

Steps in application of this principle are.....

1. Understand customer needs and expectation for products, delivery, price, dependability etc.
2. Ensure a balanced approach among customers and other stake holders (owners, people, suppliers, local communities and society at large) needs and expectations.
3. Communicate these needs and expectation throughout the organisation.
4. Measure customer satisfaction & act on results
5. Manage customer relationship

**Principle 2 – Leadership:** Leaders establish unity of purpose and direction of the organization. They should create and maintain the internal environment in which people can become fully involved in achieving the organization’s objectives.

Steps in application of this principle are.....

1. Be proactive and lead by example.
2. Understand and respond to changes in the external environment.
3. Consider the needs of all stake holders including customers, owners, people, suppliers, local communities and society at large.
4. Establish a clear vision of the organization’s future.
5. Establish shared values and ethical role module at all levels of the organisation.
6. Build trust and eliminate fear.
7. Provide people with the required resources and freedom to act with responsibility and accountability.
8. Inspiring, encouraging and recognizing people’s contributions.
9. Promote open and honest communication.
10. Educate, train and coach people.
11. Set challenging goals and targets
12. Implement a strategy to achieve these goals and targets.

**Principle 3 – Involvement of people:** People at all levels are the essence of an organization and their full involvement enables their abilities to be used for the organization’s benefit

Steps in application of this principle are.....

1. Accept ownership and responsibility to solve problems.
2. Actively seek opportunities to make improvements, and enhance competencies, knowledge and experience.
3. Freely share knowledge & experience in teams.
4. Focus on the creation of value for customers.

5. Be innovative in furthering the organization's objectives.
6. Improve the way of representing the organisation to customers, local communities and society at large.
7. Help people derive satisfaction from their work
8. Make people enthusiastic and proud to be part of the organisation.

**Principle 4 – Process approach:** A desired result is achieved more efficiently when activities and related resources are managed as a process.

Steps in application of this principle are.....

1. Define the process to achieve the desired result.
2. Identify and measure the input and output of the processes.
3. Identifying the interfaces of key activities within and between the functions of the organization
4. Evaluating risks, consequences and impacts of activities on customers, suppliers and other interested parties.
5. Establishing clear responsibility and accountability for managing key activity.
6. Identify internal and external customers, suppliers and other stake holders of the process.
7. When designing process, consider process steps, activities flows control measure, training needs, equipment, method information, material and other resources to achieve the desired result.

**Principle 5 – System approach to management:** Identifying, understanding and managing interrelated processes as a system contributes to the organization's effectiveness and efficiency in achieving its objectives.

Steps in application of this principle are.....

1. Define the systems by the identifying or developing the processes that affect a given objective.
2. Structuring a system to achieve the organization's objectives in the most effective and efficient way
3. Understanding the inter-dependencies between the processes of the system
4. Continually improving the system through measurement and evaluation
5. Estimate the resources requirements and establish resource constraints prior to action.

**Principle 6 – Continual improvement: Continual improvement of the organization’s overall performance should be a permanent objective of the organization**

Steps in application of this principle are.....

1. Make continual improvement of products, processes and systems an objective for every individual in the organization
2. Apply the basic improvement concepts of incremental improvement and break through improvement.
3. Use the periodic assessments against established criteria of excellence to identify areas for potential improvement.
4. Continually improve the efficiency and effectiveness of all processes.
5. Promote prevention based activities.
6. Provide every member of the organization with appropriate education and training, on the methods and tools of continual improvement such as the plan –do- check –act cycle, problem solving, process re- engineering, and process innovation.
7. Establishing goals to guide, and measures to track, continual improvement
8. Recognizing and acknowledging improvements.

**Principle 7 – Factual approach to decision making: Effective decisions are based on the analysis of data and information**

Steps in application of this principle are.....

1. Take measurements and collect data and information relevant to the objective.
2. Ensure that the data and information are sufficiently accurate, reliable and accessible.
3. Analyzing data and information using valid methods
4. Understand the value of appropriate statistical techniques
5. Making decisions and taking action based on factual analysis, balanced with experience and intuition.

**Principle 8 – Mutually beneficial supplier relationships: An organization and its suppliers are interdependent and a mutually beneficial relationship enhances the ability of both to create value**

Steps in application of this principle are.....



1. Identifying and selecting key suppliers
2. Establishing relationships that balance short-term gains with long-term considerations
3. Create clear and open communications.
4. Initiate joint development and improvement of products and processes
5. Jointly establish a clear understanding of customer's needs
6. Sharing information and future plans
7. Inspiring, encouraging and recognizing supplier's improvements and achievements.

**5: Quality Policy:** Key document of a quality policy or QMS that reflects an organization's commitment to quality and continual improvement. The quality policy is disseminated to all employees, is clearly posted in all facilities, and is periodically reviewed.

The quality policy is the only true definition of quality that counts in the organization. The quality policy is considered to be the driving face of the QMS as it commits your organization to meeting its objective. It is also one of the key documents against which the performance of your QMS is measured.

Policies and procedures outline the guidelines that employees must follow when performing their jobs. The goal of these procedures is to create a consistent high-quality experience for the customer. When documenting policies and procedures, there are questions that must be answered for the user: who the policies affect, what the policies are, how and when to perform them, why they must be applied and any exceptions to the rule.

## **8. Purpose**

When constructing policies and procedures, provide the reader with the purpose of the procedures. This portion will answer the "why" question. For example, a customer service policy may be to answer the phone, "Thank you for calling ABC company, this is Joseph; how may I assist you?" The purpose of the policy is to let the customer know the company he is calling, to whom he is speaking and that he has the representative's attention.

## 9. Policy/ procedure

Document the actual policy/procedure. In it, include step-by-step actions that the employee is to perform. If the employee is to use the computer, include screenshots, so the employee is aware of what he should see. Using the customer service example, if the representative must document the phone call, the screenshots should include how to access the customer's account. Write the policy/procedure from the perspective of someone who is a new employee performing the procedure for the first time.

If there are any exceptions to the policy, document that exception and how to respond to the exception.

**6. Quality Planning:** “The customer is the king”. As the quality of life improves, demand for better quality services and products also increases. Customers all over the world now demand that they be assured and satisfied that the product or services for which they are paying will meet their specifications and expectations and will perform as anticipated. In this changed environment of the economy and the industry driven by the customers, the business is open to competition worldwide. This emphasis on quality in product and services is forcing the industries to adopt internationally recognize and proven quality management systems in their operations to stay in the business. **Total Quality Management** or TQM is defined as a “management approach of an organization, centered on quality, based on participation of all its members and aiming at long-term success through customer satisfaction, and benefits to all members of the organization and to society.”

TQM is not only limited to product quality improvement but also widely cover aspects of quality in service sector too, TQM in India more than manufacturing, it is the service sector that took its time to recognize the importance of TQM. In terms of product quality improvement Garvin highlighted different important dimensions of product quality.

1. Performance – basic operating characteristics.
2. Features – “extra” items added to basic features
3. Reliability- probability product will operate over time
4. Conformance - meeting pre-established standards
5. Durability- life span before replacement
6. Serviceability – ease of getting repairs, speed & competence of repairs

7. Aesthetics – look, feel, sound, smell or taste
8. Safety- freedom from injury or harm WHEN PROPERLY USED
9. Other perceptions – subjective perceptions based on brand name, advertising, etc
10. Personnel- Hiring and training the right employees
11. Management - A ALL LAVELS implement the plans to produce the product packing, storing, shipping
12. Delivers the product to the customer in its intended from undamaged and on time.
13. Customer service –After sale follow-up

**7. Quality Policy Objective or purpose:** A list of objectives discussed at a customer focus group drawn from small businesses is shown below. These from typical quality objectives with which many businesses may identify. How many are relevant to you?

### **Quality Objectives**

1. Increase customer satisfaction
2. Reduce rework
3. Introduce quality control
4. Includes staff training
5. Encourage personal control of quality
6. Undertake staff attitude surveys
7. Reduce customer complaints
8. Reduce product returns
9. Reduce manufacturing costs
10. Reduce scraps allowance
11. Reduce bad debt
12. Reduce staff turnover
13. Improves information to workforce
14. Introduce continuous improvement
15. Keep up with technology Increase profits
16. Remove competitors from the marketplace
17. Introduce recognized quality standards
18. Introduce benchmarking
19. Undertake market research
20. Improve relations with suppliers

- 21.Improve negotiation skills with staff and suppliers
- 22.Increase knowledge of customers requirements
- 23.Help customers to identify customer requirements
- 24.Invest in new technology
- 25.Communicate through the business
- 26.Undertake internal and external quality audits
- 27.Introduce quality circles
- 28.Begin ISO9000 process
- 29.Reduce absenteeism
- 30.Improves commitments of staff to objectives
- 31.Measure effectiveness of quality programs
- 32.Increase safety awareness
- 33.Introduce staff appraisal
- 34.Introduce better customer documentation
- 35.Undertake statistical analysis

### **8. Costs of poor Quality:**

You can probably come up with several examples from your own experience of when you have come across poor quality: e.g.

- A product fails –e.g. a breakdown or unexpected wear and tear
- The product does not perform as promised (or what the customer thought was promised!)
- An order is delivered late
- Poor instructions/directions for use make using the product difficult or frustrating
- Unresponsive customer service

Poor customer service as listed above results in additional business **costs**:

- Lost customers ( expensive to replace – and they may tell others about their bad experience )
- Cost of reworking or remaking product
- Costs of replacements or refunds
- Wasted materials
- You can see from the list above that poor quality is a source of competitive disadvantage. If competitors are achieving higher quality,

then a business will suffer. The good news is that a business can benefit by improving its quality. The key benefits if improved quality are:

- Improved image & reputation ,which should result in
- Higher demand ,which may turn mean
- Greater production volumes ( possibly providing better economies of scale )
- Lower unit costs because of less waste and rejected output
- Fewer customers complaints ( & more satisfied customer )
- Potentially higher selling prices (less need to discount)

### **8. Cost Reduction through Quality Improvement:**

Improvement in quality in each n every department and in product quality should helps in reducing the production cost because the rate of rejection(ROR) is controlled to a minimum level and not only ROR is controlled to a minimum level and not only ROR is affected but quality improvement will also helpful in making good customers service etc.

Others area which are positively affected by quality improvement are.

1. Reduce costs by controlled rate of rejection.
2. Reduced employee turnover.
3. Improved employee morale.
4. Improved customer satisfaction.
5. Increased productivity.
6. A customer –focused philosophy.
7. Improved profitability.
8. Improved communications
9. More effective and efficient processes.
- 10.Increased level of accountability.

### **Quality Assurance**

**QA** is an ongoing process that requires daily attention by all laboratory staff.

Some fundamental issues in QA related to specimens include:

1. Inspection of all specimens upon receipt and before testing to ensure that they are suitable.
2. Patient information should be available on the tube

3. If the serum sample is frozen before testing, the sample must be well mixed after thawing and before testing.
4. All test results, controls and records must be checked and rechecked to ensure that the proper specimen was resulted before reporting.

QA also includes such factors as:

1. Reporting results in a timely manner
2. Being sure that the results are reported to the appropriate individual
3. Making sure that the laboratory is functioning in the most efficient way
4. Including a continuing education program for laboratory workers.
5. Evaluation of laboratory personnel to identify areas for improvement
6. Using the most reliable tests
7. Reviewing transcriptional measures.
8. Verifying final reports.

The following sections indicate components that must be continually monitored and represent fundamental aspects of a good QA program.

#### **A. Record keeping**

An efficient company will be able to monitor the records of specimens from the time samples arrive until the time that results are released. Logbooks are an essential step in the recording of laboratory specimens and should be kept confidential. Any specimen that is determined to be inadequate for testing or that does not contain that essential information e.g. for HIV testing, should not be tested and a note should be entered in the logbook. A worksheet must accompany each test run in the laboratory. The worksheet serves as a guide when placing samples on the run. QC records are important in validating laboratory results. A standard operating procedure manual should be kept in the laboratory at all times and should be reviewed and updated frequently.

#### **B. Total Quality Management**

TQM refers to a comprehensive organizational approach that is focused on continually improving the quality and efficiency with which the laboratory operates. QA is a defined program that is focused on maximizing detection of laboratory error, while TQM aims to assist in this process by maximizing efficiency. TQM is not only concerned with the monitoring of the QC/QA

program, but should also includes other technical or administrative considerations that may indirectly influence the quality and efficiency of the laboratory operation. This includes the evaluation of the laboratory staff and continuing education.

---

## **1B- Importance of quality and quality control**

### **Importance of Quality:**

Good quality helps determine a firm's success in a number of ways, and the term quality is not limited to product quality only but it covers over all functions of the firm. And it will helps in growth of business because..

1. Quality “ensures superior quality products and services.
2. Quality is essential for customers' satisfaction which eventually leads to customer loyalty.
3. Quality tools help an organization to design and create a product which the customers actually want and desires.
4. Quality ensures increased revenues and higher productivity for the organization.
5. Quality management helps organization to reduce waste and inventory.
6. As the product is perceived to be better value for money, it may command a premium price and will become more prices inelastic.
7. Fewer returns and replacements lead to reduced costs.

### **1. Quality management” ensures superior quality products and services:**

Quality of a product can be measured in terms of performance, reliability and durability. Quality is a crucial parameter which differentiates an organization from its competitors. Quality management tools ensure changes in the systems and processes which eventually result in superior quality products and services. Quality management methods such as total Quality management or six sigma have a common goal – to deliver a high quality product. Quality management is essential to create superior quality products which not only meet but also exceed customer satisfaction. Customers need to be satisfied with your brand. Business

marketers are successful only when they emphasize on Quality rather than Quantity.

Quality products ensure that you survive the cut throat competition with a smile.

## **2. Quality management is essential for customer satisfaction which eventually leads to customer loyalty.**

How do you think business run? Do businesses thrive only on new customers? It is important for every business to have some loyal customers. You need to have some customers who would come back to your organization no matter what.

Would you buy a Nokia again if the previous handset was defective? The answer is NO.

Customers would return to your organization only if they are satisfied with your products and services. Make sure that end-user is happy with your product. Remember, a customer would be happy and satisfied only when your product meets his expectations and fulfil his need. Understand what the customer expects from you? Find out what actually his need is? Collect relevant data which would give you more insight into customer's need and demands. Customer feedback should be collected on a regular basis and carefully monitored. Quality management ensures high quality products and services by eliminating defects and Incorporating continuous changes and improvements in the system. High quality products in turn lead to loyal and satisfied customers who bring ten new customers along with them. Do not forget that you might save some money by ignoring quality management processes but ultimately lose out on your major customers, thus incurring huge losses. Quality management ensures that you deliver products as per promises made to the customers through various modes of promotions.

## **3. Quality management tools help an organization to design and create a product which the customer actually wants and desires.**

## **4. Quality Management ensures increased revenues and higher productivity for the organization.**



Remember, if an organization is earning, employees are also earning. Employees are frustrated only when their salaries or other payments are not released on time. Yes, money is a strong motivating factor. Would you feel like working if your organization does not give you salary on time? Ask yourself.

Salaries are released on time only when there is free cash flow. Implementing quality management tools ensure high customer loyalty, thus better business, increased cash flow and satisfied employees, healthy workplace and so on. Quality management processes make the organization a better place to work.

Remove unnecessary processes which merely waste employee's time and do not contribute much to the organization's productivity. Quality management enables employees to deliver more work in less time.

#### **5. Quality management helps organization to reduce waste and inventory.**

It enables employees to work closely with suppliers and incorporate 'Just in Time' philosophy.

Quality management ensures close coordination between employees of an organization. It inculcates a strong feeling of team work in the employees.

**CHOOSING BEST QUALITY CONTROL METHODS-** when it comes to choose a manufacturing quality control method you need to look at a system that can adequately test the product you are manufacturing. The needs of a manufacturing company that produces steel will be much different than a company that specializes in something smaller. So how do you choose the best quality control method for your manufacturing business?

Here are a couple of common questions you can ask yourself to minimize your choice:

1. Is there anything that is causing your product to fail prematurely?  
Does the life of your product fall short of the expectations? If it does then you might benefit from product testing which aims at uncovering any weakness in the product.
2. Are you using method of measuring performance levels that does not accurately find the deviations in the quality of your product? If this is the problem then you might need to improve your method of statistical control; a quality control system that helps creates normal distribution when it comes to the quality of the product.

There is no rule that states that a company has to choose only one quality control method. Many companies have used several different method of quality assurance. If you find one that works for your company then by all means use it. If not however, you may find that mixing one or two quality control methods will work best for you.

Choosing the best quality control method for your manufacturing business can sometimes be difficult. It is a vital part of any good manufacturing business and without a good quality control method in place a system has no chance of staying in control of the worth of their product in the eyes of the consumer.

### **Different Quality control methods**

There are several different quality control methods you can choose from:

1. **Quality assurance.** Quality assurance covers all activities from design, development production, installation, servicing, and documentation. It also includes the regulation of the quality of raw materials, assemblies, products and components; services related to production; and management production, and inspection processes.
2. **Failure Testing:** this is a valuable process to perform on whole, consumer products. Tests are run on the product until it fails; it is often placed under stresses such as vibration, temperature and humidity. This

generally exposes unanticipated weakness in the product and the data is used to drive engineering and manufacturing process improvements.

3. **Statistical control:** Most manufacturing companies will use statistical control to bring the organization to six sigma levels of quality. Traditional statistical process controls in manufacturing operations usually proceed by randomly sampling and testing a fraction of the output.
  4. **Company quality:** The idea behind this was that all departments of the company approached quality with an open mind; success was possible if the management led the quality improvement process. Company-wide quality approach places emphasis on three different aspects.
  5. **Total quality control:** This is the most necessary inspection control of all in cases where sales decrease.
- 

### **1C. Quality Assurance:**

**Definition: The process that ensure production quality meets the requirements of customers**

This is an approach that aims to achieve quality by organizing every process to get the product **‘right first time’** and prevent mistakes ever happening. This is also known as a **‘zero defects’** approach.

Quality assurance is used to deliver the quality product to the client according to his requirements and budget .It makes sure that the software developed without any defects **the primary focus of QA is on facilitation, training, audits and QA reviews, thereby ensuring defect free products.**

In quality assurance, there is more emphasis on **‘self-checking’**, rather than checking by inspectors.

### **Advantages of quality assurance include:**

- Costs are reduced because there is less wastage and re-working of faculty products as the product is checked at every stage
- It can help improve worker motivation as workers have more ownership and recognition for their work ( see Herzberg)
- It can help break down ‘us and them’ barriers between workers and managers as it eliminates the feeling of being checked up on
- With all staff responsible for quality, this can help the firm gain marketing advantages arising from its consistent level of quality.

Total quality management (“TQM”) is a specific approach to **quality assurance** that aims to develop a quality culture throughout the firm. In TQM , organization consist of ‘quality chains’ in which each person or team treats the receiver of their work as if they were an external customer and adopts a target of ‘right first time’ or zero defects.

### **Importance of Quality Assurance:**

Quality assurance is a system companies use to review products, and the production system, to ensure consistent, quality results.

Manufacturing organization, as well as service industries, can employ quality assurance technique. A quality assurance system can help your company identify weakness and inconsistencies in the service or production method.

**Scrap Reduction:** Quality assurance systems identify areas that results in scrap, or products that don’t meet company specifications. When the company reduces its number of defective production, it experiences scraps reduction. Scraps reduction results in savings; identification of defects early in the production process decreases the cost to the company, because fewer man- hours and materials have been used.

**Time Efficiency:** a quality assurance team can reduce the amount of inspections required in a manufacturing organization. The quality assurance team is separate from the production group, and can therefore be objective in identifying time- wasting areas during production. They also ensure that production workers don’t use valuable production time to inspect or evaluate the production system.

**Increased Customer Satisfaction:** The quality assurance system improves the quality of products and services, which increases customer satisfaction. Customer satisfaction leads to repeat business, customer referrals, increased sales and profits. A quality assurance system eliminates defective products and continuously evaluates the process to improve products and services. Quality assurance can results in a consistently reliability in the end product results in customer satisfaction and brand loyalty. Companies’ reliability in the end product results in customer satisfaction and brand loyalty.

Companies with reliable quality gain a favourable reputation in the industry.

**Improved employee morale:** Employee morale is higher in a company using a quality assurance system, since the organization is more likely to run well, and actively seeks methods for improvement, according to the national institute of accounts. Management involves employee in the process of quality improvement. Employee becomes stakeholders in the organization and its success. Improved employee morale results in less absenteeism and turnover among workers.

**Difference Quality control or quality assurance – which is best?**

Which approach to managing quality is best? Here is a summary of the main consideration:

<b>Quality assurance</b>	<b>Quality control</b>
A medium to long-term process; cannot be implemented quickly	Can be implemented at short-notice.
Focus on processes- how things are made or delivered	Focus on outputs- work-in-progress and finished goods.
Achieved by improving production processes	Achieved by sampling & checking ( inspection)
Targeted at the whole organization	Targeted at production activities
Emphasis's the customer	Emphasis's required standards
Quality is built into the product	Defect products are inspected out

**Total quality Assurance (TQA) or total Quality Management (TQM)**

Two main objectives of total quality management are 100% customer Satisfaction and zero defects. TQM is a process beyond quality of product or services; it deals with the business philosophy of the organization. TQM propagates the concept of doing right things right and at first time itself. In TQM:

- **Total** means involvement of top management as well as workers
- **Quality** means meeting expectation of the customers

- **Management** means management of quality across the organization.

The main focus of the total quality assurance is as follow:

- Involvement of all employees in process
- Selection of suppliers
- Organization structure to support the process
- Maximum customer satisfaction
- Appropriate reward for quality improvement and suggestions

Considering above focus points, scope of TQM can be defined as follows:

- Organization should encourage building of culture promoting TQM
- Organization resources, including infrastructure should be dedicated in TQM.
- Top management decision and structure should support TQM process
- Proper Training and environment should be created before implementation of TQM.

Total quality assurance gives a great importance to customers and suppliers. Here customers and supplier both can be internal as well external. The relationship of organization with customers as well supplier is critical in continuation of TQM. Therefore, it is important to understand customers and suppliers.

### **Management Principles of total quality Assurance**

The main principles of total quality assurance are as follows:

- TQM proactively works towards prevention of quality problems.
- TQM strives to achieve a state with zero defects or minimal defects.
- TQM aims at producing right quality products at the first instance itself.
- TQM pushes the concept that quality is not the responsibility of production department but of organization as a whole.
- TQM encourages continuous improvement of business and production process.
- TQM encourage award and recognition for worker's pro-actively working towards quality.

- TQM decisions are fully based by research and data.
- TQM should be always systematic and logical in the process.

### **Types of quality assurance (program):**

In our industry of import-export of handicrafts we have mainly used two types of quality assurance program i.e. ~

- I. Internal QA program**
- II. External QA program**

### **Developing quality assurance plan:**

QA planes are developed in accordance with work done in the industry. In a industry likes us (Moradabad handicrafts) where a single firm exports wide variety of products,

The quality assurance plan has two programs

#### **1. Quality Control program**

- a. Purchasing control
- b. Production process control (fabrication, polishing, finishing, lacquering etc.)
- c. Material identification
- d. Shipment and storage
- e. Inspection and test
- f. Quality records and information feedback
- g. Non- conforming material
- h. Corrective action

#### **2. Quality Assurance Manual**

- a. Organization, authority and responsibility
- b. Design and development control
- c. Document control and QA records
- d. Vendor and subcontractor qualification
- e. Inspection and test program

## **Advantages of quality assurance program:**

*Many corporations have extensive quality control programs to ensure their product or service is consistently meeting or exceeding company expectations. While these programs are often costly to administer, they can be very beneficial.*

### **Uniformity**

Whether you are providing a product or service, any defects can have a dire impact on your bottom line, such as through losing repeat business and lowering your reputation. Quality control programs are set up to prevent or greatly reduce defects.

### **Detection in manufacturing**

Quality control programs allow companies to detect any defective products (often through software and inventory monitoring) and remove them before reaching the consumer.

### **Detection in service Industry**

Quality control or feedback surveys can be distributed to customers to monitor satisfaction levels. Business can take this information and improve (or maintain) their customer service efforts.

### **Prevention**

According to Juran's quality control handbook by J.M Juran, the cost of finding defective products averages 20 to 40 percent of total sales. Quality control programs help prevent defects by identifying issues before they occur.

### **Considerations**

According to Denver defective product litigation attorneys, thousands of people are injured each year from faulty products. Implementing a quality control program can save companies millions in potential lawsuits. This program can save companies million in potential lawsuits. These programs are especially important for certain industries, such as pharmaceutical, automobile and children's products companies.



## **Evaluation of quality Assurance**

1. Provides for quality checking and reviewing processes through all phases of product development.
2. Provides for involvement of the project manager in the control of quality.
3. Provides for adequate continuous QC during design and production.
4. Provides for the development of a project quality plan.
5. Provides for the various review types used to control the work
6. Provides for internal Quality Assurance monitoring..
7. Provides addressing, incorporation and verification of review comments and the use of a comment and response tracking form.
8. Provides for proper sub-consultant quality control (including verification of document quality).
9. Provides for the retention and filing of QA/QC check copies and records.
- 10.Requires the use of tracking and responsibility stamp or sign-off.
- 11.Requires the use of an adequate checking and back-checking system, including how to utilize the checking system.
- 12.Provides for the QC checking of manual calculations.
- 13.Provides for the QC checking of computer-generated calculations.
- 14.Provides for the QC checking of drawing s.
- 15.Provides for the QC checking of specifications.
- 16.Provides for the QC checking of quantities and cost estimate.  
Provides for the QC checking of environmental commitment and permitting requirements (including incorporation of commitments and requirement).
- 17.Provides for the QC checking of studies and reports.
- 18.Provides for the QC checking of construction stakeout reports.
- 19.Provides for a document and report format review.
- 20.Bridge quality assurance/quality control minimum requirements.
- 21.Provide for the use and submittal of development and review checklists and QC control documents

- 22. Provides a certification that QC checking has been performed in accordance with QA/QC plan.
- 23. Provides for sealing and signing of documents (i.e. plans, specification, reports, studies, etc.)
- 24. Provides for a final closeout and evaluation.

**Aspect of quality Assurance:**

Effective quality assurance systems have ten common characteristics that have been discovered in my consulting practice over the past couple of decades. This common denominator of quality management, when properly implement, can improve your organization’s ability to satisfy customer and manage your processes and products more effectively. These ten common denominators are relevant and applicable for organization seeking ISO 9001, AS 9100, ISO 13485 or TS 16949 registration.

1. **A process is in place** to ensure the needs and expectations of customers and other interested parties are clearly defined.
2. The **quality policy and quality objectives are defined, deployed** throughout the organization and understood by employee at all levels.
3. **Process are documented in simple to use procedures** that are up to date and controlled while responsibilities of personnel are established and followed upon to achieve objectives.
4. **Resources to meet objective are identifies and provided.** Resources include people, processes, equipment and infrastructure.
5. **Metrics are established and monitored for each process.** The old adage, “if it is not worth measuring, it is not worth doing,” is certainly true for business processes. **When a process is not** monitored and measured, hoe can leaders know if it is producing the desired outcomes? Many organizations fail to establish criteria for monitoring and measuring processes and as a result inefficiencies are rampant and it is very difficult to implement corrective actions that really work.
6. **Management is committed to using the metrics for process improvements** and for communications within the organization as well as for holding people accountable for their performance. Accountability is dependent upon two factors:

- 1) the people know what is expected and
- 2) The leaders' follow-up to insure people do what is expected.
- 7. A process is in place for preventing non-conforming product or service** and in the event non-conforming the situation is documented and corrective actions taken. In the case of non-conforming product, the process provides for identification and segregation to prevent it from getting to a customer.
- 8. Continual improvement is a priority and simple approaches are implemented** to involve people throughout the organization in identifying continual improvement opportunities.
- 9. A framework for verification of processes and product is in place** and functioning as planned. This includes internal audits of the processes as well as product quality verification at various stages of production.
- 10. Management is involved in the system and reviews the entire system** at appropriate intervals to insure the system is functioning as planned, is effective for the business and is being maintained. A quality management system built on these ten foundational principles will give your business a competitive advantage and should not be a bureaucratic nightmare.

**Quality assurance department:** the quality assurance department has two sections whose responsibilities are as follow;

**1. Quality Assurance section**

- A.** Establishment, maintaining and application of the in-plant standards.
- B.** Reviewing the in-plant standards by comparing actual operations with the standards
- C.** Collecting and statistically analyzing the data concerning quality control.
- D.** Necessary education and training for the people and specific personnel concerning Quality Control.
- E.** Reviewing errors in design and operation, inception of the specific items in question and suspending its operation.
- F.** Advising the selection of possible subcontractor from point of view of Quality Control.

G. Acting as a host for the Q.C promotion

**2. Quality control section**

A. Inspection and test of,

- a. Raw materials ,received
- b. Shop assembled items
- c. Fabricated individual members
- d. Welding
- e. Corrosion control (hot-dip-galvanizing)
- f. Purchased standard parts and other subcontracted products
- g. Painting
- h. Packing

B. Preparation for the inspection by the customer's inspectors and report generation.

Investigation, settlement and reporting of the defects or failures which are claimed by customers

**CHAPTER-II**

**INSPECTION: (Process of checking the quality of product)**

**INSPECTION:-**

- 1. Definition of inspection.
- 2. Objective of inspection
- 3. Stages of inspection
- 4. Inspection planning
- 5. Floor & patrol inspection
- 6. Centralize inspection
- 7. Process inspection
- 8. Final inspection
- 9. Different between inspections of quality control.
- 10.A.Q.L concept.

**1. Definition of inspection-**

According to ISO inspection is defined as an activity of measuring examining, testing or gauging (Durability) of product order to establish whether confirming is active for each characteristic product.

**2. Objective of inspection –**

- To collect information regarding the performance of the product with established standards for the use of production, purchasing and quality control.
- To sort out poor quality from good quality
- To establish and increase the reputation by protecting customers from receiving poor quality product.
- Defects source of weakness and failure in the finish products.
- To ensure that quality policy should be followed.
- To ensure that customers advised quality norms should be followed
- Successful inspection helps in time delivery of product.
- To earn reputation in the market
- To grow business volume.

### **3. stages of inspection; ( Export house or manufacture)**

- (a) Inspection of incoming material
- (b) Inspection of production process.
- (c) Inspection of finish goods,; internal-Q.C/external –QA.

#### **Inspection of production material –**

It consists of checking all the purchased part of raw material that is supplied.

Inspection of this type of takes place at supplies end or customers (factory) gate

**Inspection of production process** – Inspection of this type is done at various stages of men & machine and the critical production point.

#### **Inspection of finish goods-**

Finished and completely placed goods are inspected. It will carries out before marketing to check the quality product either rejected or sold at reduced price.

### **4. Inspection planning** – to make a system that conduct inspection.

## Inspection planning

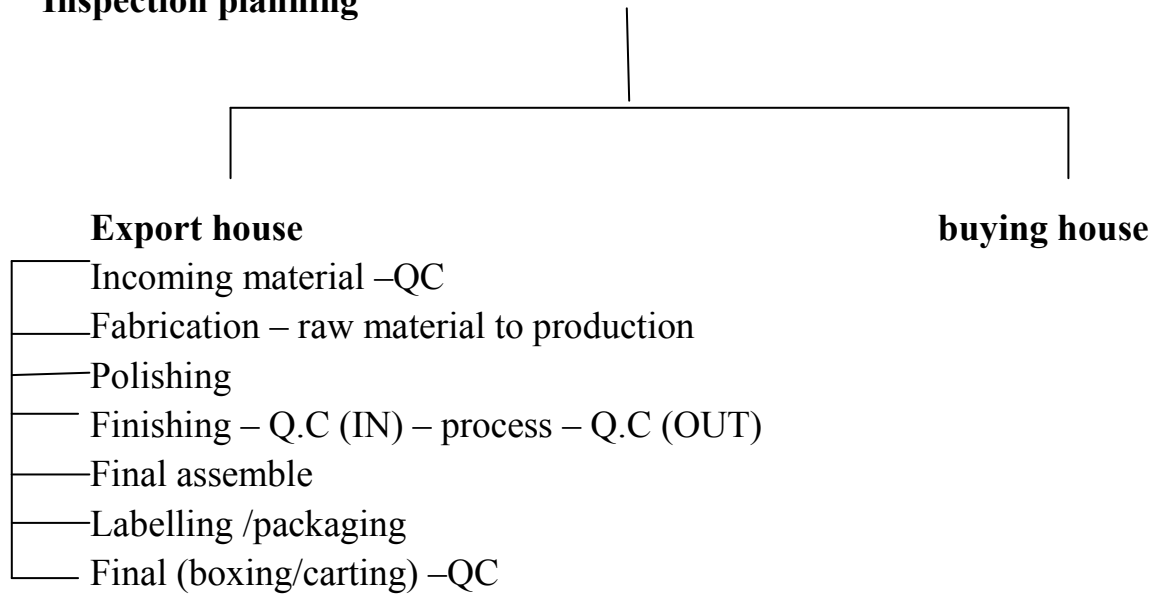

### Buying house:-

**Quality auditor:-** The inspection planning in any buying house is different and often called sample plans for quality check-

#### **1- Single stage – sample plan.**

#### **2- Double stage – sample plan**

**1- Single stage** –Dictates certain number of *piece* (n) should be drawn and that number (n) defined mainly on the size of batch.

In single stage – 100pc shipment and n pc approximately like 8pc in A.Q.L table

Major Defect's	Minor Defects
5	7
4	8

**According A.Q.L (Accepted quality load) table major defects is less than minor defects then shipment PASS and minor defects is less than major defects then shipment FAIL.**

**2- Double stage-** The inspection or world stately taking similar number of sample (n) and it number or defect in n is above certain are

Picked.14/02/2013

#### **5. Level inspection:- buying agencies**

**Order---Preproduction (5%) ---Dupro (30%) ---Random (80%) --- Shipment (100%).**

**(a) Preproduction-**

It generally follows to inspect the quality of raw material. It normally sees that factories are often used substandard raw material to lower manufacturing cost, but this can be disastrous for buyers. It identifies the production process which follows during inspection.

**(b) During production (DUPRO) Inspection –**

This type of inspection allows the buyer to have idea of average product Quality. It usually takes place once some finished product has come out of the lines. If quality issues found, what is already produced might be rework able and correcting action can be taken for the rest of the job.

**(c) Random inspection –** it takes place once production process of 100% of shipment is complete and nearly 80% of product packed. This objective is restyled to confirm a shipment quickly

**(d) Final loading inspection -**

This inspection is performed when 100% production is packed. Aim of this inspection is to identify that correct quality is packed labelling & marketing is correct. Check order quantity.

**(5) Floor inspection –**

It suggests the checking of material in process at the machine or in the production time by inspector. These inspection moves from machine to machine and from one to other work station to check the ongoing process of production. These inspectors are highly skilled and trained to use the method of inspection for minimizing. The material handling does not disturb the line layout of machinery and quickly check the defect and readily off field and correction.

**Advantages**

- (1)** Random checking may be successful than batch checking
- (2)** Does not delay in production.

(3) Save time & expense of having to more batches of work for inspection.

(4) Inspectors may see and able to report on reason of faulty work.

**(6) Patrol inspection-** this type of inspection is generally followed in the large manufacturing industries or where product is produced in different units located at different places.

**(7) Centralized inspection-**

Material which is in process of manufacturing process may be inspected and checked at centralized inspection centre which are locate one or more places in the manufacturing industries. The industries which used these inspection processes are in pharmaceutical industries, food industries.

**Advantages –**

(1) Random checking may be successful than batch checking

(2) Better quality checkups.

**(8) Final inspection or 100% inspection –**

This type is involve with correct inspection in detect of quality at each static point or stage of manufacturing where the test involved in non-disturb and every piece is separately inspected.

In this method randomly selected samples are inspected samples are taken from different batches and product. It samples more defected the entire centralized is to be rejected of reworked.

**Different between**



## Quality control

- 1- Position or raw material identification.
- 2- Dimensions & size
- 3- Colours and finishes
- 4- Construction.

## Inspection

- 1-visual quality checks.
- 2-performance test.
- 3-documentations and reporting.
- 4- packaging.

Dt15/02/2013

## CHAPTER 2

### INSPECTION

.....  
.....

#### Definition of inspection:

The term “inspection” generally refers to the activity of checking products, whereas “audit” applies to analyzing a manufacturing organization.

#### Objectives of inspection:

1. To collect information regarding the performance of the product with established standards for the use of engineering production, purchasing and quality control etc.
2. To establish and increase the reputation by protecting customers from receiving poor quality products.
3. To earn the reputation
4. To grow business volume

#### Purpose of inspection:

1. To distinguish good lots from bad lots.

2. To distinguish good pieces from bad pieces.
3. To secure products – design information.
4. To measure process capability.

### **Stage of inspection and inspection planning.**

1. Inline
2. Midline
3. Final inspection

**Inspection planning:** Inspection planning means to make a system to conduct to inspection. However the work is different in an export houses and in buying houses.

In **export houses** the inspection planning covers all the stages of production viz.

1. fabrication
2. Finishing (electroplating & colouring etc.)
3. Packing & carton stuffing.

### **Methods of inspection**

#### **100% inspection**

This type will involve careful inspection in detail of quality at each strategic point of manufacturing where the test involved is non-destructive and every piece is separately inspected. It requires more number of inspectors and hence it is a costly method.

There is no sampling error. This is subjected to inspection error arising out of fatigue, negligence, difficulty of supervision etc.

Hence complete accuracy of influence is seldomly attained.

It is suitable only when a small number of pieces are there or a very high degree of quality is required.

Example: jet engines, aircraft, medical and scientific equipment.

### **Drawbacks of inspection**

- (1) Inspection adds to the cost of the product but not for its value.
- (2) It is partially subjective, often the inspector has to judge whether a product passes or not.
- (3) Fatigue and monotony may affect any inspection judgment.
- (4) Inspection merely separates good and bad items. It is no way to prevent the production of bad items.

### **Inspection procedures:**

There are three ways of materials in process at the machine or in the production time by patrolling inspector. These inspectors move from machine to machine and from one to the other work centers. Inspectors have to be highly skilled. This method of inspection minimizes the material handling, does not disrupt the line layout of machinery and quickly located the defect and readily offers field and correction.

### **Centralized inspection**

Material in process may be inspected and checked at centralized inspection centre which are located at one or more places in the manufacturing industry.

### **Difference between inspection & quality control:**

Inspection accepts the manufacturing of non-conforming product and acts as a filter to remove it from the production flow. (Reactive system)

Quality control attempts to prevent the manufacture of non-conforming product in the first place and attempts to predict, reduce or eliminate the causes.

(Proactive system)

**Quality control** is a hierarchical plan that demonstrates how conformance is managed during various tasks and subtasks to achieve a desired goal. (Refer to ISO9001). The conformance is assessed against international standards, regulations, client data sheets else manufactures own specifications. As an example: the conformity of the following items are addressed in a quality control plan.

- a) Positive material identification
- b) Dimensions & tolerances
- c) Material chemical & mechanical properties
- d) Heat treatments
- e) Surface preparation
- f) Proof testing
- g) Fabrication quality & assembly

**Inspection** is a series of methodologies used to verify the degree of conformance. In practice, a quality control plan has various conformance requirements and corresponding inspection activities. (Refer to international standards, items under inspection & testing. As examples: the following items are inspection activities:

- 1. Visual inspection
- 2. String & performance tests
- 3. Documentation review ( MTC, Dossiers, Release Notes, Traceability)
- 4. Packaging

**AQL concept: what is AQL?**

The “AQL tables” are statistical tools at the disposal of buyers (for product inspections). They help determine two key elements:

1. How many samples should be inspected?
2. Where is the limit between acceptability and refusal, when it comes to defective products?

**Inspection level.** Different inspection levels will command different number of samples to inspect. In this article, we will stick to the so-called ‘level II’ under “normal severity”.

The AQL level appropriate for your market. If your customers accept **very few defects**, you might want to set a lower AQL for both major and minor defects.

There are basically tables. That’s you which ‘code letter’ to use. Then, the code letter will give you the sample size and the maximum numbers of defects that can be accepted.

**First table: sample size code letters**

Lot size ( number of ordered products)	General inspection levels				
			I	II	III
2	To	8	A	A	A
9	To	15	A	B	C
16	To	25	B	C	D
26	To	50	C	D	E
	To	90	C	E	F

51					
91	To	150	D	F	G
151	To	280	E	G	H
281	To	500	F	H	J
501	To	1,200	G	J	K
1,201	To	3,200	H	K	L
3,201	To	10,000	J	L	M
10,001	To	35,00	K	M	N
35,001	To	150,000	L	N	P
150,001	To	500,000	M	P	Q
500,001		And over	N	Q	R

## Chapter 2

### Quality Control in Handicrafts- Part 1

---

**Product Life Cycle:** The **product life cycle** is a concept which tells us the various stages of products during production process. Here we will discuss the product cycle of metal article.

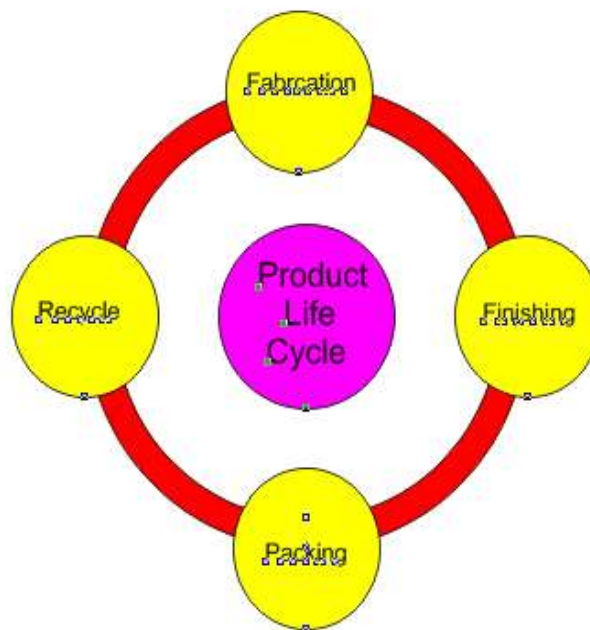

1. **Fabrication:** Fabrication is the process by which desired shapes are given to raw metal and fabrication process is done on two different type of metals i.e~ cast Metal and sheet Metals by two separate process called.
  - a. **Casting process**
  - b. **Sheet Fabrication.**

“Manufacturing or production of Items is also called  
Fabrication”

Locally We Called Fabrication Product as “Kora”

- A. **Casting Process:** Casting processes basically involve the introduction of a metal into a mould cavity, where upon solidification, the metal takes on the shape of the mould cavity.
- B. **Sheet Fabrication Process:** Production of sheet metal items is done by different machines through various process of sheet.
- 2. **Finishing:** After fabrication process we get kora products and the finishing process starts from here to finish the items in different colours as per the requirement. The finishing process is combination of different processes which are used according to requirement.
- 3. **Packing:** Packing is the process of packing the goods into its required Packing standard. This process involves labelling of products, box, and carton till final packaging.

**Stages of productions:** Production of any items involves various stages through which the items pass and below we are discussing them

- 1. **Fabrication**
- 2. **Scrapping Process ( in case of round Shape Items)**
- 3. **Emrying (Item which are not round in shape )**
- 4. **Polish**
- 5. **Ultra Sonic Cleaning (TC)**
- 6. **Finishing (Electroplating/ Antiquing /colouring/ powder Coating / Bhatti Patina)**
- 7. **Lacquering**
- 8. **Final Assembly**
- 9. **Product Labelling/ Bar- coding**
- 10. **Packing of Products**
- 11. **Carton stuffing**
- 12. **Loading/ Dispatch**

- 1. **Fabrication:** Fabrication is the process by which desired shapes are given to raw metal and fabrication process is done on two different type of metals cast metal and sheet Metals by two separate process called.

c. Casting Process



- d. Sheet Fabrication.
- e. Welding

“Manufacturing or production of Items is also called Fabrication”.

Locally We Called Fabricated Product as “Kora”

- C. Casting Process: Casting processes basically involve the introduction of a molten metal takes on the shape of the of the two main methods of casting and that are
  - a. Sand casting
  - b. Die Casting
- D. Sheet Fabrication process: Fabrication of sheet is done by different machines through various processes and these are.
  - a. Forming
  - b. Cutting
- 2. Scrapping Process: Scrapping is the process which is done to remove unevenness of outer surface of any product or to make product smooth so that the polishing can be done.  
These are of two types.
  - a. Hand Scrapping
  - b. Machine Scrapping

- 3. **Emrying**: Emrying process is also used for smoothening the outer surface of the product so that the polishing can be done. This process is done on by hand by hand by using files “Raiti” and on polishing machine grinding buffs.

Grinding process is on the items on which scrapping is not possible like Star Shape, Oval Shape, and Square Shape etc.

- 4. **Polish**: Polish process is to shine the products, the main advantage of polish is that product becomes shine as well as smooth and also the electroplating and other finishes can be done easily.
- 5. **Ultrasonic Cleaning (U.C)**: Ultrasonic cleaning is used to remove the residue of polish without harming the polish of that product. The main

advantage of this type of cleaning is that it deeply washes the product and remove maximum impurities like dust, oil etc. of the surface.

6. **Finishing / Colouring:** Finishing is the process by which coating of various

Types of colours/ shaded will be done on the product, the finishing are of many types of colour/shades will be done on the product, the finishing are of many types

- a. Electroplating (Nickel, Chrome, Pewter, silver etc.)
- b. Chemical Finishes (Antique & Patina Patina Finishes)
- c. Powder Coating
- d. Spray Panting Finishes
- e. Bhatti Patina

7. **Lacquering:** Lacquering process is used to protect the finish of the products because lacquer is a coating that is generally seen on furniture, guitars, and some wooden sculptures. **It can be matte, glossy, or resinous and can come in clear or coloured styles.**

The clear type will give the object a slightly yellow look, while coloured varieties will give the desired hue. They are mainly applied to protect the surfaces of the object the surfaces of the object from moisture, oils such as from the hands, sunlight, and bacteria and fungus that can from on wood when it gets wet. It will dry very quickly after it has been applied, and will

Produce a durable finish. Many people confuse this type of coating with a varnish coating, but it is actually different because of the durability, colour, and the chemical construction of it. The lacquer can be a natural type is manufactured directly from the lacquer gum tree, while the synthetic is made by various other chemicals in the factories. The various type of lacquering process is.

- a. **Electrophoretic Lacquers**
- b. **Dip Applied Lacquers**
- c. **Brush Lacquers**
- d. **Spray Lacquers**

8. **Final Assembly:** Final assembly means that various parts of a single item is joined together to form a single product. Other miscellaneous Fitting like felt etc. is added in this process.
9. **Product Labelling/Bar-coding:** Labelling / Bar Coding are not the process but It is the stage where product label is stick or hang on the products. These labels consist of prices, barcode and other useful information about the manufacture of the product. Labelling with necessary information is also done on product boxes and also on master cartons to recognize the product in the loading area or warehouse so that the product is recognize.
10. **Packing:** After proper labelling the product is packed in desired packing material as per the packing standard of the product. For example : A candle stand with silver finish, after labelling is packed in white cotton paper > Polybag> Bubble
11. **Box/ Carton Stuffing:** After labelling the product is packed in the required packing material and then pack in the product boxes. Then box then packed into the master carton.
12. **Loading / Dispatch:** After the carton stuffing is complete the product is shifted to the ware house or loading area for dispatch.

**Production Process of Metal Wares:** Now in this topic we discuss how the product is being done of metal wares. First of all we will discuss about...

1. **Casting:** As we have already discuss about how casting and Its type now we briefly discuss about its process.
  - a. **Sand Casting:** The sand casting process involves the use of furnace, metal, pattern, mould. The metal is melted in the furnace and then ladled and poured into the cavity of the sand Mould, which is formed by the pattern. The sand mould separate along a parting line and the solidified casting can be removed.

The process of the sand casting involves six steps. Which are described below.

1. **Mould - making** – The first step in the sand casting process is to create the mould of the casting. In an expandable mould process, this step must be performed for each casting. A mould is formed by Metal, wax, pop etc. is put into each half of the mould. The sand is packed around the pattern, which is a replica of the external shape of the casting. When the pattern is removed, the cavity that will form the casting remains. Any internal features of the casting that cannot be formed by separate cores which are made of sand prior to the formation of the mould.
2. **Clamping-** Once the mould has been made, it must be Prepared for the molten metal to be poured. The surface of the mould cavity is first lubricated to facilitate the removal of the casting. Then, the cores are positioned and the mould halves are closed and securely clamed together. It is essential that the mould halves remain security closed to prevent the loss of any material.
3. **Pouring** - The molten metal is maintained at a set temperature in a furnace. After the mould has been clamped the molten metal can be ladled from its holding container in the furnace and poured into the mould. The Pouring can be performed manually or by an automated machine. Enough molten metal must be poured to fill the entire cavity and all channels in the mould. The filling time is very short in order to Prevent early solidification of any one part of the metal.
4. **Cooling** – The molten metal that is poured into the mould will Begin to cool and solidify once it enters the cavity. When the Entire cavity is filled and molten metal solidifies, the final shape of the casting is formed. The mould cannot be opened until the cooling time has elapsed. The desired cooling time can be estimated based upon the wall thickness of the casting and the temperature of the metal cools too quickly, the part may exhibit shrinkage, cracks, or incomplete sections.

5. **Removal**- After the predetermined solidification time has passed, the sand mould can simply be broken, and the casting removed. Once removed the casting will likely have some sand and oxide layers adhered to the surface. Shot blasting is sometimes used to remove any remaining sand, especially from internal surfaces, and reduce the surface roughness.
  
6. **Trimming** – During cooling, the material from the channels in the mould solidifies attached to the casting either manually via cutting or sawing, or using a trimming press. The time require a longer trimming time. The scrap materials that result from this trimming is either discarded or reused in the sand casting process. However, the scrap material may need to be reconditioned to the proper chemical composition before it can be combined with non- recycled metal and reused.

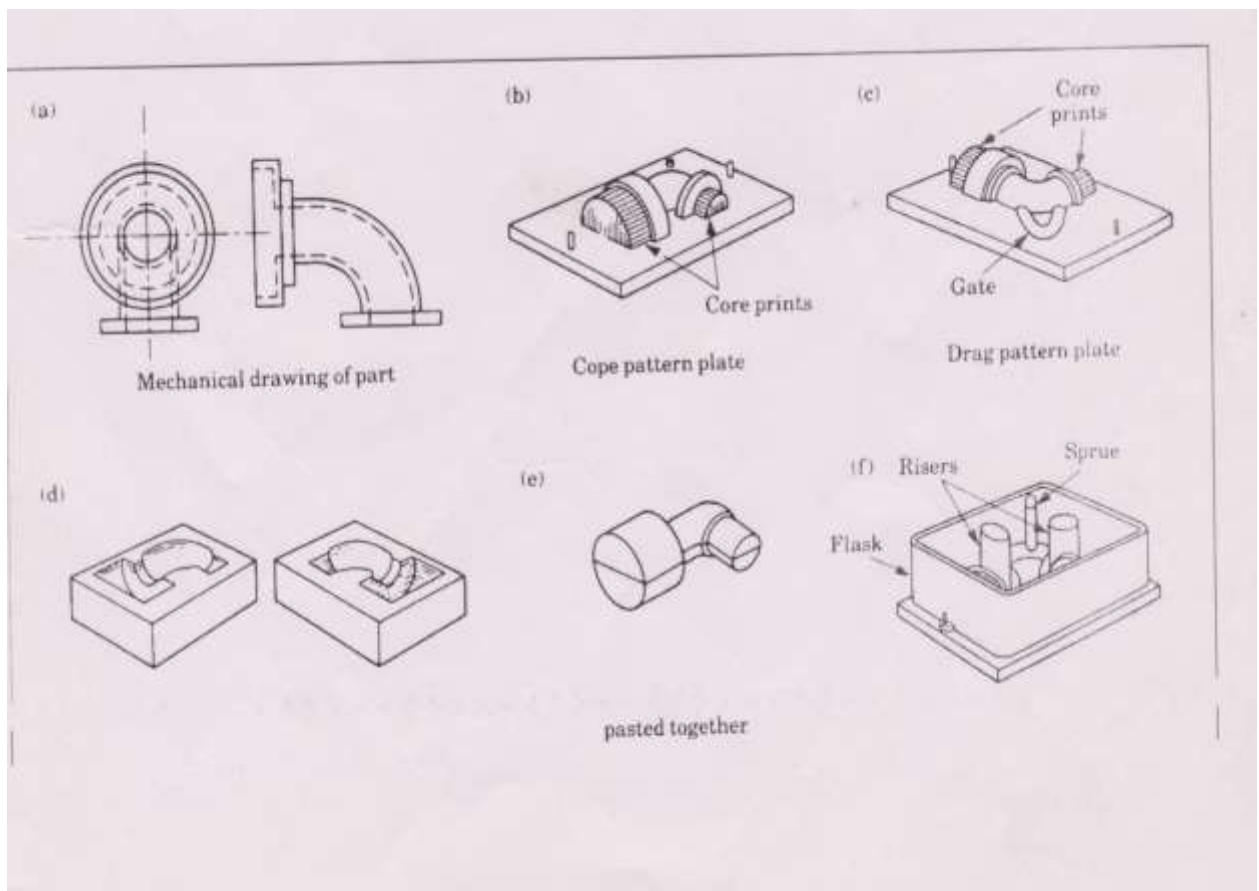



Hot Chamber Machines- Open

Hot Chamber Machines – Closed

**Process Cycle of Die Casting:** The process cycle for die casting consists of five main stages, which are explained below. The total cycle time is very short, typically between 2 seconds and 1 minute.

1. **Clamping:** The first step is the preparation and clamping of the two halves of the die. Each die half is first cleaned from the previous injection and then lubricated to facilitate the ejection of the next part. The lubrication time increase with part size, as well as the number of cavities and side- cores. Also lubrication may not be required after each cycle, but after 2 or 3 cycles, depending upon the material. After lubrication, the two die halves, which are attached inside the die casting machine, are closed and securely closed clamped together. Sufficient while the metal is injected. The time required to close and clamp the die is dependent upon the machine – larger machines (those with greater clamping forces) will require more time. This time can be estimated from the dry cycle time of the machine.
2. **Injection:** the molten metal , which is maintained at a set temperature in the furnace, is next transferred into a chamber where it can be injected into the die. The method of transferring the molten metal is dependent upon the type of die casting machine, whether a hot chamber or cold chamber machine is being used. The difference in this equipment will be detailed in the next section. Once transferred, the molten metal is injected at high pressure into the die. Typical injection pressure ranges from 1,000 to 20,000 psi. This pressure holds the molten metal in the dies during solidification. The amount of metal that is the time required to as the shot. The injection time is the time required for the molten metal to fill all of the channels and Cavities in the die. The time is very short, typically less than 0.1 seconds, in order to prevent early solidification of any one part of the metal. The proper injection time can be determined by the thermodynamic properties of the material, as well as the wall thickness of the casting machine is being used, the injection time must also include the time to manually ladle the molten metal into the short chamber.
3. **Cooling:** The molten metal that is injected into the die will begin to cool and solidify once it enters the die cavity. When the entire cavity is filled

and the molten metal solidifies, the final shape of the casting is formed. The die cannot be opened until the cooling time can be estimated from several thermodynamic properties of the metal, the maximum wall thickness of the casting, and the complexity of the die also require a longer cooling time because the additional resistance to the flow of heat.

4. **Ejection:** After the predetermined cooling time has passed, the die halves can be opened and an ejection mechanism can push the casting out of the die cavity. The time to open the die can be estimated from the dry cycle time of the machine and the ejection time is determined by the size of the casting's envelop and should include time for the casting to fall free of the die. The ejection machine must apply some force to eject the part because during cooling the part shrinks and adheres to the die. Once the casting is ejected, the die can be clamped shut for the next injection.
5. **Trimming:** - During cooling, the material in the channels of the die will solidify attached to the casting. This excess material, along with any flash that has occurred, must be trimmed from the casting either manually via cutting or sawing, or using a trimming press. The time required to trim the excess material can be estimated from the size of the casting's envelop. The scrap material that result from this trimming is either discarded or can be reused in the die casting process. Recycled material may need to be reconditioned to the proper chemical

**2. Scrapping process:** scrapping is the process which is done after casting process, the basic purpose of this process is to remove unevenness, of outer surface of any product or to make product smooth so that the polishing can be done. This process is basically done by machines called scrapping machine or "**chillai machine**". (*Scrapping machines: A scrapping machine installed on the ground connected to electric motor by a shaft & V belt which joins the machine & motor*). There are mainly 3 types of scrapping process.

1. **Hand scrapping:** hand scrapping is done by hand with a hand tool (randa)
2. **Machine scrapping:** when scrapping is done by machine it is called machine scrapping.
3. **Lathe scrapping machines:** scrapping is also done lathe machines and it done on lathe machine as well and it depends on the product which types of scrapping are used. See the picture of lathe machine below



**3. Emrying (items which are not round in shape):** Emrying process is used for Smoothing the outer surface of the products so that the polishing can be done. **This process is done on by hand by using files “raithi” and on polishing machines by using different emrying buffs.** Emrying process is on the items on which scrapping is not possible like star shapes, oval shape, square shape etc.

**Types of Emrying:**

- A. Stone emrying “local word ~ pathar ki shaan”:** in this process the outer surface of the item is grind till it is smooth by using stone buff. There are all types of stone buffs are available in market in all sizes. This emrying is useful when you need to grind a large amount of metal from a item or if you want to reduce the size of the item.
- B. Emrying by using cloth or leather buffs “local word~ kapre pr chamre ki shaan”:** in this type of emrying, the item is grind by using cloth or leather buffs. The plain cloth buffs are available in all sizes on the polish material shops. These buffs are made by using adhesive called “sares” and by putting a carbon powder on the cloth or leather buffs.
- C. Lancer emrying:** In this emrying process, the sand paper is used on the buffs like we use carbon powder as above. The processes are same as above.
- D. Sand paper emrying “local word~ raigmaal”:** sand paper is used by hand or by machine for emrying where as it required.
- E. Filing “local word~ raithi”:** filing process is completely done by hand it is used grind the area where scrapping or emrying is not possible. There are many types of files in various shapes and sizes.

**4. Polish:** polishing is a process that can either be done by hand or with a polishing machine. This aim of polishing is to create a shiny and smooth surface of an object by rubbing it or using some sort of chemical action. Once polished a surface will have a significant specula reflection. With objects made from materials such as glass, metal or stone, the polishing process will also reduce the diffuse reflection to a minimum.

**The wheels or bobs** are dressed with abrasive grain (emery, aluminium oxide or silicon carbide) using glue or cement as adhesive.

## **POLISHING MOPS**

A wide range of fabric are used in the manufacture of polishing mops and these, in order of hardness, include:

- a. Cotton** – in various qualities from soft, unbleached cloths to fast cutting, white fabrics incorporating special dressing, generally known as calico mops. And white stitched mops
- b. Sisal** – an extremely hard fibre generally used in conjunction with abrasive grease based composition. The type of mop using 100% woven sisal with cloth interleaves to protect and separate each section is called a stapol mop.
- c. Scotchbright\* or Fibral\*\***- a low density abrasive material provides a simple and effective method of cleaning materials and for producing a satin finish. This is tough, chemically resistant material composed of tough fibres to which evenly distributed aluminium oxide abrasive grains are resin bonded. These mops can be used dry with relatively light pressure. They are available in a number of grades but generally come in coarse, medium and fine. The use of too high a mop pressure can result in overheating of the mop face and cause fusing of the synthetic fibres.
- d. Leather** – these mops are occasionally used in the traditional trade for the final finishing of non-ferrous metals. Generally chamois leather mops are used in the jewellery trade with a rouge composition for the polishing of gold and silver.

**5- Ultra Sonic Cleaning (TC):** An ultra sonic cleaning tank is simply a metal tank [stainless steel] that has pizo ceramic transducers bonded to the bottom or side. These transducers have a unique property of changing size almost instantly when excited by an electrical signal. When excited the transducer increase in size and causes the tank bottom or side to move. This creates a compression wave in the liquid of the tank.

By using an electrical generator that puts out a high frequency signal [20 to 50 kHz] the transducer rapidly includes compression and rarefaction waves in the liquid.

During the rarefaction cycle the liquid is torn apart. This creates a vacuum cavity reaches a certain size [based on the frequency and the wattage of the signal] the cavity can no longer retain its shape. The cavity collapses violently and creates a temperature of 5,000 degrees centigrade and a jet of plasma that impacts against whatever objects so in the tank. There are millions of these bubbles created and collapsing every second in an ultrasonic tank.

### **Compression & rarefaction waves in an ultrasonic tank:**

It is these collapses that clean the part. The jet will explode the dirt or any other material off the surface of the part. by adding soap or other chemical to the water in an ultrasonic tank, you can increase the effectiveness of the cleaning operation heat also improves ultrasonic cleaning by eliminating entrapped air in the water and making the detergent more effective. The best temperature to clean with is 80% of the boiling temperature of the solution. You should always use a basket to hold the parts you are cleaning .never put parts directly on the bottom of an ultrasonic cleaner.

## **6. Finishing (electroplating /antiquating /colouring /powder/coating/ bhatti patina)**

### **a. Electroplating process:**

The process of electroplating (also referred to as electrode position) is fairly simple. To start, a negative charge is placed on the object that will be coated. The object is then immersed in a salt solution of the metal that will because to plate the object. From there, it's simply a matter of attraction; the metallic ions of the salt are positively charged and are attracted to the negativity charged object. Once they connect, the positivity charged ions revert back to their metallic form again, resulting in newly electroplated objects.

Controlling the thickness of the plating is generally achieved by alternating the time the object spends in the salt solution. The longer it remains inside the bath, the thicker the shell becomes. of course, there must also be an adequate amount of metallic ions in the bath to continue coating the objects. the shape of the object will also have an effect on the thickness , and sharp corners will be plated thicker than recessed area. This is due to **electric current** in the bath and how it flows denelier around corners.

### **B. antiquing:**

1. Oxidized copper or copper OX items have been plated to a muted rich copper and then oxidized to appear old.
2. Oxidized sterling silver or silver OX items have been plated to sterling silver and then oxidized to make them look old.
3. Oxidized brass or brass OX items have been plated to a smooth brass finish over raw brass and then oxidized to appear old.

### **C. colouring:**

The process of coating of synthetic paint layer is called colouring. The two main methods of colouring are

- a. hand painting
- b. Spray painting.

**7. Lacquering:** lacquering process is used to protect the finish of the products because lacquering act as protective cover of the item and preserve the item finish. Lacquer is a coating that is generally seen on furniture, guitars, and some wooden sculptures. **it can be matte, glossy , or resinous and can come in clear or coloured styles.**

The clear type will give the object a slightly yellow look, while coloured varieties will give the desired hue. They are mainly applied to protect the surface of the object from moisture, oils such as from on wood when it gets wet. it will dry quickly after it has been applied, and will produce a durable finish . Many people confuse this type of coating with a **varnish** coating, but it is actually different because of the durability, colour and the chemical construction of it. **The lacquer can be a natural or in synthetic form.** the natural types is manufacture red directly from the lacquer gum tree, while the synthetic is made by various other chemicals in the factories. The various types of lacquering process are.

- a. **Electrophoretic lacquers**
- b. **dip applied lacquers**
- c. **brush lacquers**
- d. **spray lacquers**

## 8. Final assembly

### 4. areas of major defects of product:

Areas of major Defects	Types of defects to measure
<p><b>a. Design &amp; structure:</b> measurement is always as per sketch &amp; structure as proportional as per the design drawing.</p>	<ol style="list-style-type: none"> <li>1. un-stability in structure</li> <li>2. un- proportional products</li> </ol>
<p><b>b. Sizes &amp; Dimensions:</b> The size plays the very vital role in any of the product since oversize or undersize product may cause very serious problem like miscalculation of volume, de-sizing of packaging materials and result in financial losses.</p>	<ol style="list-style-type: none"> <li>1. Over size dimensions</li> <li>2. under size dimensions</li> </ol>
<p><b>c. Odors:</b> the product should be free of paint smell, fumigants, textile, ink, soil, repellents, mould or cigarette smoke. Be sure to air product adequately before packing for shipment.</p>	<ol style="list-style-type: none"> <li>1.It tarnished the quality of finish</li> <li>2.bad smells</li> <li>3.fungus</li> <li>4.rust</li> </ol>
<p><b>d. Raw material:</b> the raw material used is always as per the standard or instruction however there is no instant of checking the quality of raw material by naked eye but it should be complied with the test report of raw material</p>	<ol style="list-style-type: none"> <li>1.Health concern due lead &amp; other poisonous impurities</li> <li>2. Poor quality finishes</li> <li>3. Fickle (inconsistent) structure</li> </ol>
<p><b>E .Finish:</b> The finishes are matches as per the sample products.</p>	<ol style="list-style-type: none"> <li>1. No visible hook marks, wire, clamp, string, stand mark.</li> <li>2. No visible scratch mark, lines finger print are accepted.</li> <li>3. Shine or matt should be proper</li> <li>4. Consistency in shades</li> <li>5. Check that packet of silica gel is present if the items have any fear</li> </ol>

	of moisture like wood, iron etc.
<b>F. colour:</b> The colour match as per the approved sample.	<ol style="list-style-type: none"> <li>1. Lines, scratches, colour fade, unevenness in colour layer will not be accepted.</li> <li>2. Dust particles should not be present on the outer surface.</li> </ol>
<b>G. Labelling :</b> price sticker, price tag, barcode etc. should be placed/hanged at advised place	<ol style="list-style-type: none"> <li>1. Check the description and other details on sticker/ Tag with advised sample.</li> <li>2. Sticker should be properly pasted and at appropriate place.</li> <li>3. Barcode should be scanned with barcode gun.</li> </ol>
<b>h. Packaging:</b> packaging, material & method box/ cartons are should be as per the approved standard	<ol style="list-style-type: none"> <li>1. Packaging material should be as per the approved standard (bubble, paper, tape, cotton, etc.)</li> <li>2. packaging method should be approved</li> <li>3. in case of colour box check the colour, strength, labelling and dimensions (if item is properly fitted)</li> <li>4. Busting strength of Box &amp; Caron to be as per the advised norms. (150 PSI,200 PSI)</li> <li>5. Check the ply strength of Box &amp; Carton (5/7 ply box/carton)</li> <li>6. Check the colour of box &amp; carton example brown</li> </ol>

	<p>or white</p> <p>7. check the colour of adhesive tape in which product is packed, gift box (generally no tapping), product box and master carton</p> <p>(Tapping of master carton is always as per the approved colour.</p> <p>8. Check the details of marking of product, box, inner box, Master carton.</p> <p>9. Check if box/carton marking label is pasted at appropriate place.</p> <p>10. Check the inner qty &amp; master key qty as well.</p>
<p><b>i. Storage:</b> place where the shipment are kept for loading it is also called ware house.</p>	<p>1. Check the moisture level doesn't exceed of wall and floor</p> <p>2. Check that the area is properly ventilated and dry.</p>

**6. Techniques for quality control in production:** production quality control techniques can be classified into three categories basically.

<b>Fabrication</b>	<b>Finishing</b>	<b>Packing</b>
<p><b>Fabrication by casting:</b></p> <p>1. Mould should have properly filed and have appropriate thickness.</p> <p>2. Sand should be properly powdered and wet (by lubricates). Improper wet/ grind sand should lead to defect like flash, short casting, mould shift,</p>	<p><b>Electroplating:</b></p> <p>1. current is proper,</p> <p>2. Use pure anode.</p> <p>3. Salt is pure.</p> <p>4. proper after agents is used</p> <p>5. Item is properly polished (no scratches etc).</p> <p>6. Item is properly washed free from oil, grease, dust etc.</p> <p>7. lacquer should be</p>	<p><b>Labelling:</b></p> <p><b>Points to check in the desc. of sticker/tag</b></p> <p>1. Check the colour, shapes &amp; size of sticker/tag.</p> <p>2. check the qty</p> <p>3. check item description</p> <p>4. Scan the barcode.</p> <p>5. Check the placement of sticker or tag.</p>

<p>etc.</p> <p>3. the mould case should be of appropriate size to hold sand</p> <p><b>Scrapping:</b></p> <ol style="list-style-type: none"> <li>1. Thickness should not be thin or thick</li> <li>2. proper tools for minimum tool marks</li> </ol>	<p>done in dust free cabin</p> <ol style="list-style-type: none"> <li>8. Lacquered item should be dry in oven at proper temperature.</li> <li>9. in case of silver electroplating use butter paper instead that colour should not be properly stick o the item</li> </ol>	
<p><b>Drilling &amp; punching: Oversized or unmatched drilling effected the assembly of product</b></p> <ol style="list-style-type: none"> <li>1. proper scaling is done before drilling or punching</li> <li>2. Make a mould for item so that drill/punch will be perfect at each time.</li> <li>3. Place the mould on flat surface on the drill machine.</li> <li>4. Check at every n times the accuracy of mould &amp; drilled/punch hole or cut.</li> </ol>	<p><b>Colour:</b></p>	<p><b>Master Cartons</b></p>



<p><b>Emrying improper emrying leads to poor quality of polish, most of the emery marks cannot be removed in polishing.</b> To avoid scratches proper density of sand wheel is used.</p> <p><b>Polishing: Improper finished leads to poor quality of finish like electroplating.</b> Polish remove most of the scratches.</p>	<p><b>Patina</b></p> <p><b>Enameling</b></p>	
---	--	--

## Chapter 4

### Product Packaging

---

---

#### **Definition of packaging:**

Packaging is defined in the regulation as “all products made of any materials of any nature to be used for the containment Protection, handling, delivery and preservation of goods from the procedure to the user or consumer.”

The main packaging materials used are:

- Paper
- Acetate
- Cotton
- Plastic
- Styrofoam
- Foam
- Corrugated Paper Sheet

#### **Other Material used by other industries.**

- Glass-Food and Pharmacy Industries
- Steel-Food and Pharmacy Industries
- Aluminium-Food, Pharmacy Industry, Cosmetic

Wood Packaging and packaging made from other materials (for example hessian, jute, cork, ceramics and so on) are also included.

Packaging is the process of enclosing, or containing the product in bottles, plastic, wrappers, lubes, paper cartoons and boxes etc. For the purpose of displaying useful information regarding the product, its content, weight, size, price, constituents, usage necessary instruction about the usage and storing the product must be recorded on the package. Package reduces the risk of wastage, spoilage, leakage, metage and evaporation etc. in the process of transportation storage.

## **Importance of Package**

**1. Protection:** The fundamental function of packaging are to protect it from sun, rain, moisture, insects and atmospheric contracts etc. packaging maintain the product fresh and enhances its life. So, we use air-tight containers for certain product.

**2. Easy Identification:** Every producer has its own distinct packaging, different from other with respect to design, size, colour and other specification packaging help-us in the easy identification and immediate picking up of the product.

**3. Convenience:** Packaging provides convenience in the transportation and storage of the product. It is convenient for the consumer to use these products. Packaging of Tropicana Real and Fruity Juices facilitates their consumption. Packaging, no doubts helps in the safe

**4. Sales Promotion:** It is rightly said that packaging works as silent, salesmen. It catches the attention of customers, who pick up the product, go through its description and are induced to purchase the product. Self service is becoming more and more common in the field of shopping, where the customer picks up the product himself and makes its payments on the counter. Packaging in these circumstances promotes the sales.

**5. Image Building:** Packaging builds image of the product and its producers. The effective packaging is the source of prestige to its producers. Packaging continues to be more important in the modern growing completion, open, and display of the product and self service of the customers. The producers sometime developed innovative ideas about packaging which promotes their sales. For examples, shampoo, tomato ketchup, surf, sugar, milk, oil etc. are sold in small pouches.

### **Types of product Packaging:**

Product packaging depends on the type of product. In handicraft major types of packaging used are given below.

- 1. Cardboard Packaging:** It is difficult to find a retail store that does not have procures ducts package in cardboard boxes. Benefiting from plentiful supply and in expensive source materials, cardboard is used to package many consumer goods. Some online sellers are introducing

cardboard-based packaging in lieu of less easy-to-open option like blister packs.

**a. Normal Corrugated Pack (Brown/White)**

**b. Gift Box Pack**

**c. Colour Box Pack**

**2. Acetate Packaging:**

**a. Display Pack**

**b. Gift Pack**

**3. Blister Pack:** Blister packs provide individual protection for the product, while providing the manufacturer with marketing opportunities on the packing itself. Medication is often packaged in blister packs. Tablets, pills and action figures are typical products that reach consumer by way of a blister pack. **Chinese suppliers mainly used this type of packing method to pack their product because it is cost effective.**

**4. Tamper-evident packaging:** Restricted or dangerous products may be protected by tamper-evident packaging. Medications are the mostly common found product using tamper-proof packaging. Tamper-evident sealing measure is also used on shipping containers, especially in the wholesale trade of goods. Shrink-wrap is also a very common type of tamper-evidence material that's overlooked by many people.

**5. Wooden Packaging:** Item is packed into wooden boxes.

**6. Plastic Carton Packaging:** Plastic carton are one of the most durable forms of product packaging and come in an array of sizes, colours and designs. Plastic cartons are used to hold product such as milk, cleaning solutions and condiments such as mayonnaise, mustard and ketchup and are also used to protect a number of beauty products and perfumes. Most plastic cartons are made from high density polyethylene (HDPE), a durable plastic that is safe for food containment and is designed to protect products such as milk from spoiling due to direct sunlight and heat. HDPE is also very durable and is the preferred method of transport due to its strength and resistance to cracking.

**7. Recycled Carton Packaging:** As a result of the growing concern regarding climate change and the environment, more Americans are becoming

environmentally aware. As a result, recycled cartons have become more prevalent. According to an article published on Earth 911, over 85% of the Earth's population has access to community recycling. Recycled paper and plastic products can be used to make cartons for food products, beauty and hair care products and chemicals.

### **International Standard of Packaging:**

Each industry have different standard of packing according to international norms and some of which applies to handicraft industry by most of retail stores which is listed below.

- 1. Articles should have proper price tag/stickers with readable font and font size.**
- 2. Each items have scan able barcode.**
- 3. Each item if (greater than 6") packed in poly bag should have child suffocation warning label printed on poly-bag “Warning: To avoid danger of suffocation, keep this plastic bag away from babies and children. Do not use this bag in cribs, beds, carriages or playpens. The plastic bag could block nose and mouth and prevent breathing. This bag is not a toy.”**
- 4. Product must have appropriate product warning sticker or hang tag for example Candle Warning for Candle Holder & Accessories, CE/UL warning for electrical accessories and table ware product have “dishwasher safe” warning(if prd. Is not dishwasher safe warning will be not for dishwasher)**
- 5. Every warning should have in 3/6 international language which is English, Spanish, French, Dutch, Chinese, Arabic or in the language advised by customer.**
- 6. Proper identification mark on master carton, inner box label, product box label should be present.**

### **Marking and Labelling**

**Complete marking must comprise the following three parts:**

- 1. Shipping mark**

1. Identification mark: e.g. initial letters of receiver or shipper or of receiver's company name.
2. Identification number: e.g. receiver's order number.
3. Total number of items in the complete consignment
4. Number of the package in the consignment, e.g. 5/12 or 5-12.
5. Place and port of destination.

## 2. Information mark

**Country of Origin:** The country of origin must be stated in accordance with the provisions of the particular countries statement of the country of origin is often mandatory. In some cases it is not desired and, if contractually agreed, may even have to be omitted. Failure to comply with such agreements entails a risk of blacklisting.

**Indication of weight of package:** From a gross weight of 1000 kg, packages must be marked with details of weight.

With regards to ease of transport, handling and storage, the relevant standards also recommend indicating weight from a lower threshold.

**Dimensions of packages:** Standards specify that dimensions be stated in centimetres.

## 3. Handling Instructions

“Handling marks” help to ensure that greater care is taken with cargo handling. It must be possible to tell.

- Whether the package is sensitive to heat or moisture.
- Whether it is at risk of breakage.
- Where the top and bottom are and where the centre of gravity is located.
- Where loading tackle may be slung.
- The symbols for package handling instruction are internationally standardization in ISO R/780 (International organization for standardization) and in DIN 55 402(DIN, German Institute for standardization). The symbols must never be omitted as they are self-explanatory and so overcome language problems in international transport options.

## Labelling

Like packaging, labelling should also be done with extra care. It is also important for an exporter to be familiar with all kinds of sign and symbols and should also maintain all the nationally and internationally standards while using these symbols. Labelling should be English, and words indicating country of origin should be as large and as prominent as any other English wording on the package or label.

Labelling on product provides the following important information:

- Shipper's mark
- Country of origin
- Weight marking (in pounds and in kilograms)
- Number of packages and size of cases (in inches and centimetres)
- Handling marks (international pictorial symbols)
- Cautionary markings, such as "This Side Up"
- Port of entry
- Labels for hazardous materials

Labelling of a product also provides information like how to use, transport, recycle or dispose of the package or product. With pharmaceuticals, food, medical, and chemical product, some types of information are required by governments.

It is better to choose a fast dyes for labelling propose. Only fast dyes should be used for labelling. Essential data should be in black and subsidiary data in a less conspicuous colour ; red and orange and so on. For food packed in sacks, only harmless dyes should be employed, and the dye should not come through the packing in such a way as to affect the goods.

### Type of Carton Labels:

**UCC (Uniform Code Council) Labels:** The purpose of GS1-128 (formerly known as UCC-128) is to establish a standard way of labelling a package with more information than just a product code. It provides supplemental information such as batch number and "use before "dates.

There are two main components of UCC/EAN/GS1-128: the data with its Application identifier and the bar code symbology used to code the data. The

bar code symbology is code 128. The difference is the use of defined Application Identifiers with data encoded into the code 128 symbol.

Types of export packaging:

1. **Loosed or Unpacked (Used by Vehicle Industry):** Loose or unpacked is a common choice for large items such as heavy vehicles. These Unpacked, or break-bulk, goods are carried as general cargo instead of in containers. This increase the risk of damage during the goods to prevent damage from movement, moisture or other causes.
2. **Drums (Used by Chemical Industry):** Drums can be made of stainless steel, polyethylene, continuous- cast carton steel or all fibber and come in various size. They are commonly used for transporting liquids, powder or goods that need to be kept dry.
3. **Boxes or Creates (Used by Food, Electronic & Small Product Industry):** Boxes or crates comprise the most popular shipping options. Boxes and Crates are often confused with one another when they are both made of wood. For a container to be a crate, All six of its sides must be in place to result in the rated on the weight it can carry before the top and sides are installed .The boxes and crates are usually stacked on pallets and shrink wrapped for stability. If more durability is required, the boxes or crates are also containerized. Containerization and shrink wrapping also prevent goods from being stolen or tampered with.
4. **Containers (Used by Frozen Food Industry):** Because they are easy to pack and move, containers are used to transport most exported goods. Containers are standardized metal boxes that can withstand the weight of cargo. Dimension of the containers very but the standard containers are 40- foot dry freight, 20- foot reefer container (industry language for the term “refrigerated container”). The goods inside still might need packaging, but containers provide added protection and increased security from theft.
5. **Pallets (Used by small product industry):** Pallets allow smaller boxes and cartons to be grouped together. They easy to transport by fork lift trucks, which makes the process of loading, unloading and warehousing easier. Cartons because it`s easy, reliable and low cost. Pallets and containers provide the most efficiency with excellent cargo protection.

**Concept of Drop Test:** Item has been completely packed as per the standard in carton and then drop from certain height from each side of the carton.



For the Carton Drop Test, there are two standard can be referred, the international safe transit Association (ISTA) 1A and 2A. Normally most of clients use the specification of ISTA 1A, the drop procedures of ISTA 1A, and 2A are the same (ISTA1A.....10 Drops .....6 flat, corner, 3 edges), but their drop heights are different.

**Drop Height**

The test drop height varies with the weight of the packaged-product:

Packaged- Product					Drop height free fall			
<=		<			1A	2A		
lbs	Kg	lbs		Kg	In	mm	In	mm
0	0	21		10	30	769	38	970
21	10	41		19	24	610	32	810
41	19	61		28	18	460	28	660
61	28	100		45	12	310	20	810
100	45	150		68	8	200	12	310

**Drop procedur**

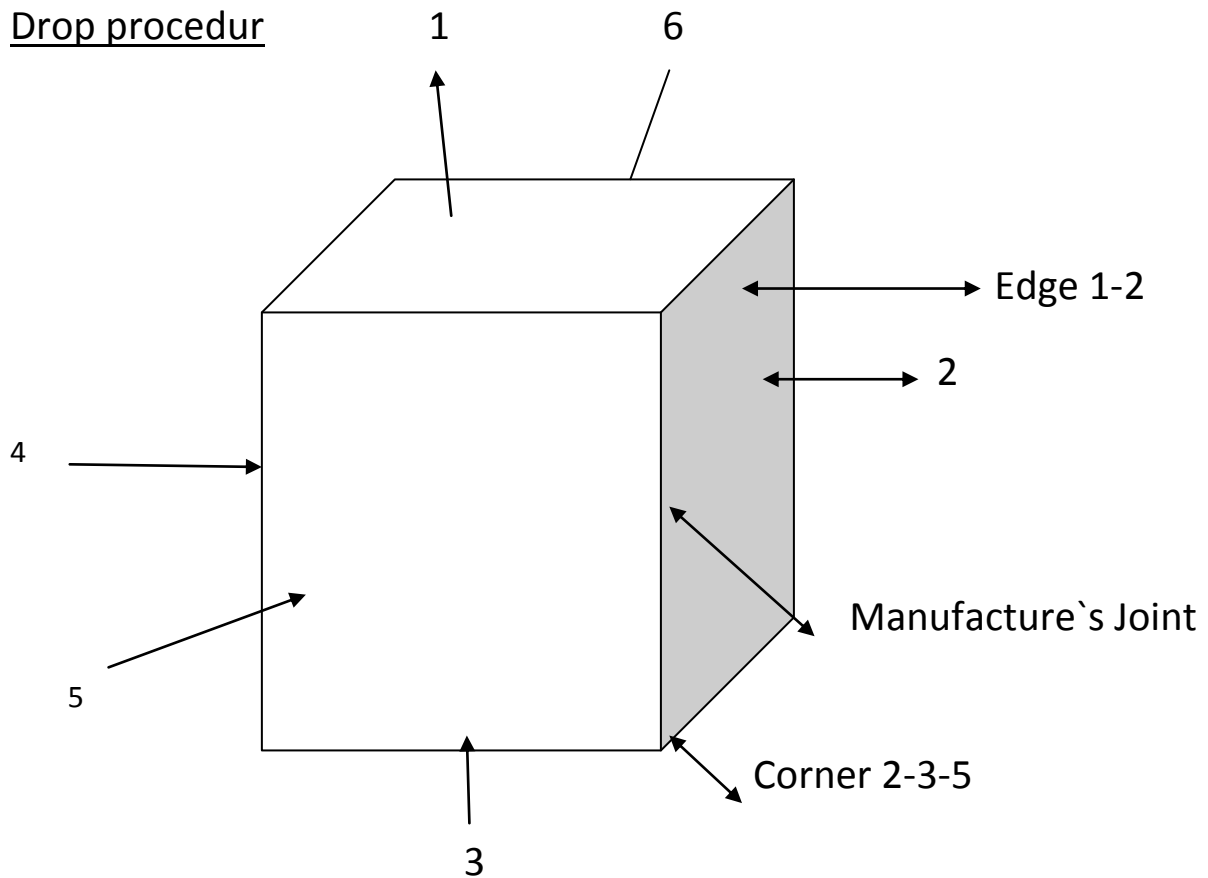

Sequence #	Orientation	Specific face, edge or corner
1	Corner	most fragile-3 corner if not known test 2-3 -5
2	Edge	shortest edge radiating from the corner tested
3	Edge	next longest edge radiating from the corner tested
4	Edge	longest test radiating from the corner tested
5	Face	one of the smallest faces
6	Face	opposite small face
7	Face	one of the medium faces
8	Face	opposite medium face
9	Face	one of the largest faces
10	Face	opposite large face

### **Concept of Vibration Test: to be done in laboratory**

**ISTA:** International Safe Transit Association (ISTA) to conduct packaging testing to many requirements for its “Transit Tested” certification program, allowing members organizations to label their packaging and allowing non-members to obtain test reports verifying compliance.

### **Concept of Transit Test:**

**This test is performed in lab only and it includes**

- 1. Checking of packing material against hazardous material**
- 2. Checking of packing qty in master carton**
- 3. Drop test, vibration test, pressure test**
- 4. Labelling & marking instruction**
- 5. Proper warning labels**

## **6. Busting strength of corrugated cartons**

### **Advantages of Packing Testing**

- Protect the product
- Save money. Each time your product is damaged during shipping, You Lose Money
- Increase Brand Loyalty
- Reduce the Need for Trial shipments
- Reduce Product Claim Headaches

Packaging testing can be done many stages of the product cycle: prior to new product launch, with new packaging redesigns, when product damage is an issue in your company, or when your clients require testing. The best way to prepare is to include testing as early in the packaging design as possible. Packaging testing equipment includes rotary vibration, random vibration, incline impact ramp, mechanical shock, and free fall drop tester. Plus, our environmental chambers allow us to conduct a number of tests such as:

Compression testing to assess warehousing stacking and load;

Shock testing to assess handling, drop and impact;

Vibration testing to assess transportation vibration;

Atmosphere testing to assess environmental effects

(Temperature, humidity and pressure)